

# TRENDS

CONCRETE • WOOD • MAJOLICA



La materia Ergon interpreta le tendenze contemporanee dell'interior design: definisce le forme architettoniche e coordina gli ambienti in sintonia con uno stile di vita moderno e dinamico. Il tempo scandisce i pensieri ed i gesti che accompagnano le attività della giornata e lo spazio ne accoglie il succedersi. Le linee, i colori e la materia si animano: il risultato evoca una vera e propria scenografia, in cui Tr3nd non solo arricchisce gli ambienti, ma ne è anche l'incredibile protagonista.

Un giorno come tanti, unico e irripetibile.



LA BELLEZZA  
È LA TUA DOTE  
NATURALE  
PERCHÉ LA  
TUA ESSENZA  
È SOBRIA,  
LUCENTE,  
SEDUCENTE.

08 | 00



SAND NEEDLE / 30F83RB / 30x30 - 11<sup>13/16</sup>" x 11<sup>13/16</sup>"  
TAUPE MAJOLICA / 13F77 / 12,5x25 - 4<sup>15/16</sup>" x 9<sup>13/16</sup>"  
BROWN WOOD / 54F96R / 20x120 - 7<sup>7/8</sup>" x 47<sup>1/4</sup>"



SAND NEEDLE

TAUPE MAJOLICA

BROWN WOOD



ASSAPORARE LA VITA  
INTENSAMENTE,  
GUSTANDO APPIENO  
LA SUA GRANDE  
VERSATILITÀ.



09 | 00







GREY MAJOLICA / 13F78 / 12,5x25 - 4<sup>15/16</sup>" x 9<sup>13/16</sup>"  
 SMOKE WOOD / 54F95R / 20x120 - 7<sup>7/8</sup>" x 47<sup>1/4</sup>"  
 SMOKE CONCRETE / N9F85R / 90x90 - 35<sup>7/16</sup>" x 35<sup>7/16</sup>"

09 | 30

OGNI GIORNO  
ESPRIMI TE  
STESSA, DAI  
VITA A PICCOLI  
E GRANDI  
PROGETTI,  
ESAUDISCI OGNI  
TUA ESIGENZA.



IVORY MAJOLICA / 13F71 / 12,5x25 - 4<sup>15</sup>/<sub>16</sub>" x 9<sup>13</sup>/<sub>16</sub>"  
BROWN MAJOLICA / 13F76 / 12,5x25 - 4<sup>15</sup>/<sub>16</sub>" x 9<sup>13</sup>/<sub>16</sub>"  
SAND CONCRETE / N9F83R / 90x90 - 35<sup>7</sup>/<sub>16</sub>" x 35<sup>7</sup>/<sub>16</sub>"  
SAND WOOD / 28F93R / 20x180 - 7<sup>7</sup>/<sub>8</sub>" x 70<sup>7</sup>/<sub>8</sub>"



IVORY MAJOLICA

BROWN MAJOLICA

SAND CONCRETE

SAND WOOD





11 | 00



DECIDERE, ACCORDARE,  
PERFEZIONARE.  
LA BELLEZZA È NEI MINIMI  
DETTAGLI DI STILE.



PURE WHITE MAJOLICA / 06F74 / 6x25 - 2<sup>3</sup>/<sub>8</sub>" x 9<sup>13</sup>/<sub>16</sub>"  
GREY CONCRETE / 60F88R / 60x60 - 23<sup>5</sup>/<sub>8</sub>" x 23<sup>5</sup>/<sub>8</sub>"

PURE WHITE MAJOLICA

GREY CONCRETE



IVORY MAJOLICA / 13F71 / 12,5x25 - 4<sup>15</sup>/<sub>16</sub>" x 9<sup>13</sup>/<sub>16</sub>"  
SAND CONCRETE / C3F83R / 120x120 - 47<sup>1</sup>/<sub>4</sub>" x 47<sup>1</sup>/<sub>4</sub>"





BLACK MAJOLICA / 13F79 / 12,5x25 - 4<sup>15</sup>/<sub>16</sub>" x 9<sup>13</sup>/<sub>16</sub>"  
WHITE CONCRETE / C3F80R / 120x120 - 47<sup>1</sup>/<sub>4</sub>" x 47<sup>1</sup>/<sub>4</sub>"

IL RELAX É VIVERE  
L'ATMOSFERA DI SPAZI  
CALDI E AVVOLGENTI.



21 | 00



PURE WHITE MAJOLICA / 06F74 / 6x25 - 2<sup>3</sup>/<sub>8</sub>" x 9<sup>13</sup>/<sub>16</sub>"  
BROWN WOOD / 27F96R / 26,5x180 - 10<sup>7</sup>/<sub>16</sub>" x 70<sup>7</sup>/<sub>8</sub>"  
BROWN WOOD / 28F96R / 20x180 - 7<sup>7</sup>/<sub>8</sub>" x 70<sup>7</sup>/<sub>8</sub>"



## Majolica caldi

### Majolica Shiny

12,5x25 - 4<sup>15/16</sup>"x9<sup>13/16</sup>"



12,5x25 (4<sup>15/16</sup>"x9<sup>13/16</sup>"  
13F71 IVORY ● 57



12,5x25 (4<sup>15/16</sup>"x9<sup>13/16</sup>"  
13F73 SAND ● 57



12,5x25 (4<sup>15/16</sup>"x9<sup>13/16</sup>"  
13F77 TAUPE ● 57



12,5x25 (4<sup>15/16</sup>"x9<sup>13/16</sup>"  
13F76 BROWN ● 57

## Majolica freddi

### Majolica Shiny

12,5x25 - 4<sup>15/16</sup>"x9<sup>13/16</sup>"



12,5x25 (4<sup>15/16</sup>"x9<sup>13/16</sup>"  
13F70 WHITE ● 57



12,5x25 (4<sup>15/16</sup>"x9<sup>13/16</sup>"  
13F78 GREY ● 57



12,5x25 (4<sup>15/16</sup>"x9<sup>13/16</sup>"  
13F75 SMOKE ● 57



12,5x25 (4<sup>15/16</sup>"x9<sup>13/16</sup>"  
13F79 BLACK ● 57

### Majolica Shiny

6x25 - 2<sup>3/8</sup>"x9<sup>13/16</sup>"



06F74 PURE WHITE ● 57



# Concrete



**BATTISCOPIA - SKIRTING**  
7,5x60 (2<sup>15/16</sup> x 23<sup>5/8</sup>)  
Pcs. Box. 15 - MI x Box 9

**87F81R** IVORY NAT. RETT. ● 16  
**87F83R** SAND NAT. RETT. ● 16  
**87F87R** TAUPE NAT. RETT. ● 16  
**87F86R** BROWN NAT. RETT. ● 16  
**87F80R** WHITE NAT. RETT. ● 16  
**87F88R** GREY NAT. RETT. ● 16  
**87F85R** SMOKE NAT. RETT. ● 16  
**87F89R** BLACK NAT. RETT. ● 16



**BATTISCOPIA - SKIRTING**  
4,6x90 (1<sup>13/16</sup> x 35<sup>7/16</sup>)  
Pcs. Box. 8 - MI x Box 7,20

**B3F81R** IVORY NAT. RETT. ● 23  
**B3F83R** SAND NAT. RETT. ● 23  
**B3F87R** TAUPE NAT. RETT. ● 23  
**B3F86R** BROWN NAT. RETT. ● 23  
**B3F80R** WHITE NAT. RETT. ● 23  
**B3F88R** GREY NAT. RETT. ● 23  
**B3F85R** SMOKE NAT. RETT. ● 23  
**B3F89R** BLACK NAT. RETT. ● 23

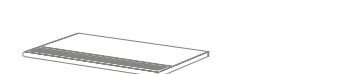

**GRADINO - STAIR TREAD**  
33x60 (12<sup>15/16</sup> x 23<sup>5/8</sup>)  
Pcs. Box. 6 - MI x Box 3,60

**71F81R** IVORY NAT. RETT. ● 56  
**71F83R** SAND NAT. RETT. ● 56  
**71F87R** TAUPE NAT. RETT. ● 56  
**71F86R** BROWN NAT. RETT. ● 56  
**71F80R** WHITE NAT. RETT. ● 56  
**71F88R** GREY NAT. RETT. ● 56  
**71F85R** SMOKE NAT. RETT. ● 56  
**71F89R** BLACK NAT. RETT. ● 56

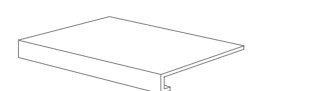

**GRADONE - STEP**  
33x60x3,2x3,2  
(12<sup>15/16</sup> x 23<sup>5/8</sup> x 1<sup>1/4</sup> x 1<sup>1/4</sup>)  
Pcs. Box. 4 - MI x Box 2,40

**1CF81R** IVORY NAT. RETT. ● 89  
**1CF83R** SAND NAT. RETT. ● 89  
**1CF87R** TAUPE NAT. RETT. ● 89  
**1CF86R** BROWN NAT. RETT. ● 89  
**1CF80R** WHITE NAT. RETT. ● 89  
**1CF88R** GREY NAT. RETT. ● 89  
**1CF85R** SMOKE NAT. RETT. ● 89  
**1CF89R** BLACK NAT. RETT. ● 89



**ANGOLARE - CORNER TILE**  
33x33x3,2x3,2  
(12<sup>15/16</sup> x 12<sup>15/16</sup> x 1<sup>1/4</sup> x 1<sup>1/4</sup>)  
Pcs. Box. 2 - MI x Box 0,66

**1AF81R** IVORY NAT. RETT. ● 96  
**1AF83R** SAND NAT. RETT. ● 96  
**1AF87R** TAUPE NAT. RETT. ● 96  
**1AF86R** BROWN NAT. RETT. ● 96  
**1AF80R** WHITE NAT. RETT. ● 96  
**1AF88R** GREY NAT. RETT. ● 96  
**1AF85R** SMOKE NAT. RETT. ● 96  
**1AF89R** BLACK NAT. RETT. ● 96



**GRADONE - STEP**  
33x120x3,2x3,2  
(12<sup>15/16</sup> x 47<sup>1/4</sup> x 1<sup>1/4</sup> x 1<sup>1/4</sup>)  
Pcs. Box. 2 - MI x Box 2,40

**CRF81R** IVORY NAT. RETT. ● 139  
**CRF83R** SAND NAT. RETT. ● 139  
**CRF87R** TAUPE NAT. RETT. ● 139  
**CRF86R** BROWN NAT. RETT. ● 139  
**CRF80R** WHITE NAT. RETT. ● 139  
**CRF88R** GREY NAT. RETT. ● 139  
**CRF85R** SMOKE NAT. RETT. ● 139  
**CRF89R** BLACK NAT. RETT. ● 139

# Fashion Wood

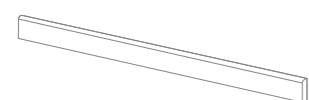

**BATTISCOPIA - SKIRTING**  
4,6x120 (1<sup>13/16</sup> x 47<sup>1/4</sup>)  
Pcs. Box. 6 - MI x Box 7,20

**B4F91R** IVORY NAT. RETT. ● 33  
**B4F93R** SAND NAT. RETT. ● 33  
**B4F97R** TAUPE NAT. RETT. ● 33  
**B4F96R** BROWN NAT. RETT. ● 33  
**B4F90R** WHITE NAT. RETT. ● 33  
**B4F98R** GREY NAT. RETT. ● 33  
**B4F95R** SMOKE NAT. RETT. ● 33  
**B4F99R** BLACK NAT. RETT. ● 33

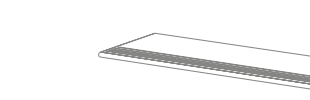

**GRADINO - STAIR TREAD**  
33x120 (12<sup>15/16</sup> x 47<sup>1/4</sup>)  
Pcs. Box. 6 - MI x Box 2,40

**74F91R** IVORY NAT. RETT. ● 120  
**74F93R** SAND NAT. RETT. ● 120  
**74F97R** TAUPE NAT. RETT. ● 120  
**74F96R** BROWN NAT. RETT. ● 120  
**74F90R** WHITE NAT. RETT. ● 120  
**74F98R** GREY NAT. RETT. ● 120  
**74F95R** SMOKE NAT. RETT. ● 120  
**74F99R** BLACK NAT. RETT. ● 120

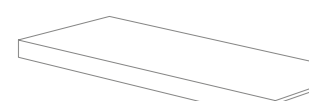

**GRADONE - STEP**  
33x120x3,2x3,2  
(12<sup>15/16</sup> x 47<sup>1/4</sup> x 1<sup>1/4</sup> x 1<sup>1/4</sup>)  
Pcs. Box. 2 - MI x Box 2,40

**CRF91R** IVORY NAT. RETT. ● 139  
**CRF93R** SAND NAT. RETT. ● 139  
**CRF97R** TAUPE NAT. RETT. ● 139  
**CRF96R** BROWN NAT. RETT. ● 139  
**CRF90R** WHITE NAT. RETT. ● 139  
**CRF98R** GREY NAT. RETT. ● 139  
**CRF95R** SMOKE NAT. RETT. ● 139  
**CRF99R** BLACK NAT. RETT. ● 139

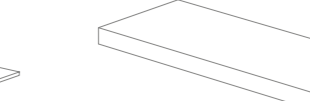

**ANGOLARE - CORNER TILE DX / SX**  
33x120x3,2x3,2  
(12<sup>15/16</sup> x 47<sup>1/4</sup> x 1<sup>1/4</sup> x 1<sup>1/4</sup>)  
Pcs. Box. 1 - MI x Box 1,20

**ACF91RD / ACF91RS** IVORY NAT. RETT. ● 142  
**ACF93RD / ACF93RS** SAND NAT. RETT. ● 142  
**ACF97RD / ACF97RS** TAUPE NAT. RETT. ● 142  
**ACF96RD / ACF96RS** BROWN NAT. RETT. ● 142  
**ACF90RD / ACF90RS** WHITE NAT. RETT. ● 142  
**ACF98RD / ACF98RS** GREY NAT. RETT. ● 142  
**ACF95RD / ACF95RS** SMOKE NAT. RETT. ● 142  
**ACF99RD / ACF99RS** BLACK NAT. RETT. ● 142

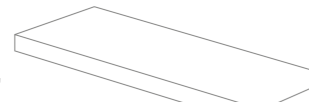

**GRADONE - STEP**  
33x120x3,2x3,2  
(12<sup>15/16</sup> x 47<sup>1/4</sup> x 1<sup>1/4</sup> x 1<sup>1/4</sup>)  
Pcs. Box. 1 - MI x Box 1,20

**ACF81RD / ACF81RS** IVORY NAT. RETT. ● 142  
**ACF83RD / ACF83RS** SAND NAT. RETT. ● 142  
**ACF87RD / ACF87RS** TAUPE NAT. RETT. ● 142  
**ACF86RD / ACF86RS** BROWN NAT. RETT. ● 142  
**ACF80RD / ACF80RS** WHITE NAT. RETT. ● 142  
**ACF88RD / ACF88RS** GREY NAT. RETT. ● 142  
**ACF85RD / ACF85RS** SMOKE NAT. RETT. ● 142  
**ACF89RD / ACF89RS** BLACK NAT. RETT. ● 142

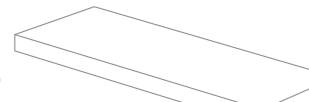

**ANGOLARE - CORNER TILE DX / SX**  
33x120x3,2x3,2  
(12<sup>15/16</sup> x 47<sup>1/4</sup> x 1<sup>1/4</sup> x 1<sup>1/4</sup>)  
Pcs. Box. 1 - MI x Box 1,20

**ACF81RD / ACF81RS** IVORY NAT. RETT. ● 142  
**ACF83RD / ACF83RS** SAND NAT. RETT. ● 142  
**ACF87RD / ACF87RS** TAUPE NAT. RETT. ● 142  
**ACF86RD / ACF86RS** BROWN NAT. RETT. ● 142  
**ACF80RD / ACF80RS** WHITE NAT. RETT. ● 142  
**ACF88RD / ACF88RS** GREY NAT. RETT. ● 142  
**ACF85RD / ACF85RS** SMOKE NAT. RETT. ● 142  
**ACF89RD / ACF89RS** BLACK NAT. RETT. ● 142

# Majolica



**BECCO CIVETTA - BULLNOSE**  
12,5x25 (4<sup>15/16</sup> x 9<sup>13/16</sup>)  
Pcs. Box. 26





**113F71** IVORY NAT. ● 9  
**113F73** SAND NAT. ● 9  
**113F77** TAUPE NAT. ● 9  
**113F76** BROWN NAT. ● 9  
**113F70** WHITE NAT. ● 9  
**113F78** GREY NAT. ● 9  
**113F75** SMOKE NAT. ● 9  
**113F79** BLACK NAT. ● 9



**BECCO CIVETTA - BULLNOSE**  
6x25 (2<sup>3/8</sup> x 9<sup>13/16</sup>)  
Pcs. Box. 74

**106F74** PURE WHITE NAT. ● 7

## DRY - PRESSED CERAMIC TILES ISO 13006 ANNEX G - UNI EN 14411 ANNEX G - Bla UGL

CARATTERISTICHE TECNICHE Technical Features - Caracteristiques Techniques - Technische Eigenschaften Technische Eigenschaften - Características Técnicas - Технические Характеристики		NORMA Standard - Norme Norm - Norma - Norma	VALORI Value - Valeur Vorgabe - Valor - Средние
	<b>PLANARITÀ</b> Flatness - Planéité - Ebenflächigkeit - Planiyud - Плоскостность	UNI EN ISO 10545/2	± 0,26% / ± 1,5 mm
		ASTM C485 WARPAGE	-
		CALIBRATED ± 0,75% (MAX ± 0,09 in)	-
		RECTIFIED ± 0,40% (MAX ± 0,05 IN-SIZE ≤ 60 cm) (MAX ± 0,07 IN-SIZE > 60 cm)	± 0,25% (MAX ± 0,05 IN-SIZE ≤ 60 cm) (MAX ± 0,07 IN-SIZE > 60 cm)
	<b>ASSORBIMENTO D'ACQUA (VALORE MEDIO IN %)</b> Water absorption (Average value expressed in %) - Absorption d'eau (Valeur moyenne en %) Wasseraufnahme (Durchschnittswert in %) - Absorción de agua (Valor medio en %) Поглощение воды	UNI EN ISO 10545/3 ≤ 0,5 % ASTM C373	CONFORME  COMPLIANT
	<b>RESISTENZA ALLA FLESSIONE</b> Modulus of rupture - Resistance a la flexion - Biegefestigkeit Resistencia a la flexion - Прочность на изгиб	UNI EN ISO 10545/4	≥ 50 N/mm <sup>2</sup>
	<b>FORZA DI ROTTURAZIONE</b> Breaking strength - Résistance à la rupture - Bruchlast - Resistencia a la rotura - Разрывное усилие	UNI EN ISO 10545/4 ASTM C648	≥ 2000 N 700 Lbs
	<b>RESISTENZA AL GELO</b> Frost resistance - Résistance au gel - Frostbeständigkeit Resistencia a las heladas - Морозостойкость	UNI EN ISO 10545/12 ASTM C1026	CONFORME UNAFFECTED
	<b>RESISTENZA CHIMICA</b> <b>AD ALTE E BASSE CONCENTRAZIONI DI ACIDI E BASI</b> Chemical resistance to high and low acid and basic concentrations Résistance chimique aux hautes et basses concentrations d'acides et de bases Chemikalienfestigkeit bei hohen und niedrigen Konzentrationen von Säuren und Basen Resistencia química con concentraciones altas y bajas de ácidos y bases Химическая стойкость к высоким и низким концентрациям кислот и щелочей	UNI EN ISO 10545/13 ASTM C-650	ULA - UHA - UA  UNAFFECTED
	<b>RESISTENZA ALLE MACCHIE</b> Stain resistance - Résistance aux taches - Fleckenbeständigkeit Resistencia a las manchas - Стойкость к образованию пятен	UNI EN ISO 10545/14 CTI 81-7D	5 NO EVIDENT VARIATION
	<b>COEFFICIENTE DI ATTRITO</b> Slip resistance - Coefficient de glissement - Rutschfestigkeit Barfußbereich Coeficiente de atrito medio - Коэффициент трения		<b>CONCRETE/WOOD</b>   <b>MAJOLICA</b>
		DIN 51130	R10   -
		DIN 51097	B (A+B)   -
		ANSI A 137.1- 2012 DCOF (SECTION 9.6)	WET ≥ 0,42   -
		B.C.R.A.	≥ 0,40   -

Per maggiori chiarimenti sui dati tecnici e sulla garanzia consultare il catalogo generale in vigore.  
For further information on technical specifications, please consult our up-dated general catalogue.  
Pour toutes informations supplémentaires sur les données techniques et sur les garanties, veuillez consulter le catalogue général en vigueur.  
Für weitere Informationen über technische Daten und Garantie beziehen sie sich bitte auf den aktuellen Gesamtkatalog.  
Para ulteriores informaciones sobre los datos técnicos y la garantía, vease el catalogo general en vigor.  
Более подробную информацию о технических данных и гарантии смотрите в действующем сводном катал.





SHADE VARIATION



Moderate

Articolo	Formato (cm)	Spessore (mm)	Pz. x Mq.	Pz. x Scat.	Mq. x Scat.	Peso x Scat. (Kg)	Scat. x Pal.	Mq. x Pal.	Peso x Pal. (Kg)
Item	Size (cm)	Thickness (mm)	Pieces x Sqm	Pieces x Box	Sqm x Box	Weight x Box (Kg)	Boxes x Pal.	Sqm x Pal.	Weight x Pal. (Kg)
Reference	Format (cm)	Epaisseur (mm)	Pcs / M <sup>2</sup>	Pcs / Bte	M <sup>2</sup> / Bte	Poids / Bte (Kg)	Bte / Pal.	M <sup>2</sup> / Pal.	Poids / Pal. (Kg)
Artikel	Format (cm)	Stärke (mm)	Stk. x Qm	Stk. x Krt.	Qm x Krt.	Gewicht x Krt. (Kg)	Krt. x Pal.	Qm x Pal.	Gewicht x Pal. (Kg)
Articulo	Tamaño (cm)	Espesor (mm)	Pzs x Mc.	Pzs x Caja	Mc. x Caja	Peso x Caja (Kg)	Cajas x Pal.	Mc. x Pal.	Peso x Pal. (Kg)
Артикул	Формат (cm)	Толщина (mm)	Шт. x Кв.М.	Шт. x Кор.	Кв.М. x Кор.	Вес x Кор. (Kg)	Кор. x Подд.	Кв.М. x Подд.	Вес x Подд. (Kg)
20F8_R	80X180	10	0,69	2	2,880	63,36	20	57,60	1267
27F9_R	26,5X180	10	2,10	3	1,431	31,68	36	51,52	1140
28F9_R	20X180	10	2,78	4	1,440	31,68	40	57,60	1267
C3F8_R	120X120	10	0,69	1	1,440	33,12	30	43,20	994
98F8_R	60X120	10	1,39	2	1,440	35,00	22	31,68	770
54F9_R	20X120	10	4,17	4	0,960	23,50	36	34,56	846
N9F8_R	90X90	10	1,23	2	1,620	36,00	18	29,16	648
60F8_R	60X60	10	2,78	3	1,080	25,00	40	43,20	1000
63F8_R	30X60	10	5,56	6	1,080	25,00	40	43,20	1000
30F8_RB	30X30	10	11,11	12	1,080	25,00	40	43,20	1000
M63F8_R	30X60	10	5,56	4	0,720	16,00	30	21,60	480
I30F8_R	30X30	10	11,11	5	0,450	10,42	60	27,00	625
13F7_	12,5X25	9	32,00	26	0,810	16,00	81	65,61	1296
06F74	6X25	9	66,67	34	0,510	10,20	99	50,49	1010
H305Y_R	30x30	10	11,11	5	0,450	10,42	60	27,00	625



07.30  
08.00  
09.00  
09.30  
10.15  
11.00  
11.30  
16.15  
17.00  
18.00  
21.00

## ENGLISH

AN ELEGANTLY LIVED DAY.  
A SOPHISTICATED WOMAN.  
INSPIRING INTERIORS.

Ergon interprets contemporary trends in interior design: it highlights architectural features and coordinates rooms in tune with a modern, dynamic lifestyle. Time defines the daily sequence of ideas and actions, while space contains their flow. Lines, colours and matter itself come to life: the result is a beautiful backdrop for daily living, where Tr3nd not only decorates rooms but is also their key feature of stunning loveliness.

Just an ordinary day,  
unique and unrepeatable.

### 07.30

Waking up is pure sensual pleasure. An elegant mix of colours, materials and emotions to be enjoyed.

### 08.00

Beauty comes naturally to you; your innermost being is tasteful, gleaming, seductive.

### 09.00

Savour life to the full, experiencing all its immense versatility.

### 09.30

You express your personality every day, start projects, big and small, and fulfil all your needs.

### 10.15

A strong, complex personality, you always find a creative solution to the challenges of daily life.

### 11.00

Choosing, matching, perfecting. Beauty lies in the tiniest stylistic details.

### 11.30

Posed to express great aesthetic versatility.

### 16.15

Combinations of style are your strong point. You know how to select and use them to best effect. Elegant nuances that free the imagination.

### 17.00

You are form and content. Because every perfect aesthetic conceals a refined, cultured soul.

### 18.00

Your home mirrors your personality. Warm, welcoming, modern and minimalist. It is a real pleasure to live there.

### 21.00

Relaxation means soaking up the mood of warm, cosy locations.

## FRENCH

UN JOUR D'ÉLÉGANCE.  
UNE FEMME SOPHISTIQUEE.  
DES CADRES DE GRANDE INSPIRATION.

La matière Ergon donne une voix aux tendances contemporaines de la décoration d'intérieur : elle définit les formes de l'architecture et coordonne les espaces, en symbiose avec un style de vie moderne et dynamique. Le temps rythme les pensées et les gestes qui accompagnent les activités de la journée, et l'espace est le lieu où tout se produit. Les lignes, les couleurs et la matière prennent vie : le résultat constitue une authentique scénographie, où Tr3nd non seulement embellit les espaces, mais en est la vedette absolue.

Un jour comme tant d'autres,  
unique et exceptionnel.

### 07.30

Le réveil est pur plaisir des sens. Un assortiment raffiné de couleurs, de matières et d'émotions à vivre.

### 08.00

La beauté est pour toi un don naturel, parce que tu as une nature discrète, éclatante, séduisante.

### 09.00

Croquer la vie à pleines dents pour goûter à sa grande diversification.

### 09.30

Chaque jour, tu te réalises, tu crées des petits et grands projets, tu écoutes tes envies.

### 10.15

Une personne organisée qui sait ce qu'elle veut, qui sait faire preuve de créativité pour gagner les défis quotidiens.

### 11.00

Choisir, accorder, perfectionner. La beauté réside dans les petits détails de style.

### 11.30

Poser pour exprimer une grande polyvalence esthétique.

### 16.15

Les accords chics sont ton point fort. Tu sais comment choisir et mettre en valeur. Des nuances élégantes pour déchaîner la fantaisie.

### 17.00

Tu es forme et contenu. Parce que derrière une esthétique parfaite se cache un esprit cultivé et raffiné.

### 18.00

La maison est le miroir de ta personnalité. Chaleureuse, accueillante, moderne et minimaliste. La vivre est un véritable plaisir.

### 21.00

Se relaxer, c'est vivre l'ambiance d'espaces chaleureux et captivants.

## DEUTSCHE

EINE ELEGANTE FRAU.  
INSPIRIERENDE RAUMWELTEN.

Die Kollektion von Ergon interpretiert die heutigen Trends der Innenarchitektur. Sie definiert architektonische Formen und gestaltet den Raum in Übereinstimmung mit einem modernen, dynamischen Lifestyle. Gedanken und Gesten, die den Alltag begleiten, fügen sich in Raum und Zeit. Linien, Farben und Material erwachen zu Leben und inszenieren Stilwelten, in denen Tr3nd nicht nur Gestaltungselement, sondern Hauptakteur ist.

Ein Tag wie so viele andere.  
Einzig und einmalig.

### 07.30

Erwachen und genießen. Sanftes Erwachen in einem stimmungsvollen Ambiente. Farben und Materialien verbreiten ein elegantes Licht.

### 08.00

Schönheit gehört zu dir, denn du bist pur, schlicht, verführerisch.

### 09.00

Das Leben intensiv und in allen Facetten genießen.

### 09.30

Jeden Tag verwirklichst du dich. Lässt du kleine und große Projekte entstehen. Wirst du deinen Erfordernissen gerecht.

### 10.15

Als charakterstarke, komplexe Persönlichkeit meisterst du kreativ alle Herausforderungen des Alltags.

### 11.00

Entscheiden, abstimmen, vervollkommen. Schön bis ins kleinste Detail.

### 11.30

Das Abbild einer vielfältigen Ästhetik.

### 16.15

Stilkombinationen sind deine Stärke. Dein Look stimmt immer. Elegante Nuancen bieten mannigfaltige Möglichkeiten.

### 17.00

Du bist Inhalt und Form. Denn hinter einer perfekten Ästhetik verbirgt sich stets ein kultiviertes, feinsinniges Wesen.

### 18.00

Das Zuhause ist der Spiegel der Seele. Warm, behaglich, modern und minimalistisch: Wohlbefinden pur.

### 21.00

Entspannung steht für Wohlgefühl in einer behaglichen und wohnlichen Raumatmosphäre.

## ESPAÑOL

UN DÍA VIVIDO CON ELEGANCIA.  
UNA MUJER SOPHISTICADA.  
ÁMBITOS PLENAMENTE  
ESTIMULANTES.

La materia Ergon interpreta las tendencias contemporáneas del interiorismo: define las formas arquitectónicas y coordina los espacios de acuerdo con un estilo de vida moderno y dinámico. El tiempo marca el ritmo de los pensamientos y los gestos que acompañan las actividades del día y el espacio alberga su sucesión. Las líneas, los colores y la materia se animan: el resultado evoca una verdadera escenografía en la que Tr3nd no solo enriquece los ámbitos, sino que además es su increíble protagonista.

Un día como tantos, único e irreplicable.

### 07.30

El despertar es puro placer de los sentidos. Una elegante mezcla de colores, materias, emociones que vivir.

### 08.00

La belleza es tu dote natural porque tu esencia es sobria, brillante, seductora.

### 09.00

Saborear la vida intensamente, disfrutando plenamente su gran versatilidad.

### 09.30

Cada día expresas tu propia persona, das vida a pequeños grandes proyectos, satisfaces cada una de tus exigencias.

### 10.15

Carácter decidido y complejo, sabes superar con creatividad los desafíos cotidianos.

### 11.00

Decidir, acordar, perfeccionar. La belleza reside en los mínimos detalles estilísticos.

### 11.30

Posando para expresar una gran versatilidad estética.

### 16.15

Tu fuerte son las combinaciones de estilo. Sabes cómo elegirlas y valorizarlas. Elegantes tonalidades para dar rienda suelta a la imaginación.

### 17.00

Eres forma y contenido. Porque detrás de una estética perfecta se revela un alma culta y refinada.

### 18.00

El hogar es el espejo de tu personalidad. Cálido, acogedor, moderno y minimalista. Vivirlo es un auténtico placer.

### 21.00

La relajación es vivir la atmósfera de espacios cálidos y envolventes.

## RUSSIAN

ДЕНЬ В ЭЛЕГАНТНОМ СТИЛЕ.  
ИЗЫСКАННАЯ ЖЕНЩИНА.  
ВПЕЧАТЛЯЮЩИЕ ИНТЕРЬЕРЫ.

Продукция Ergon выражает современные тенденции в дизайне интерьеров: она вычерчивает архитектурные формы и согласованно оформляет помещения в соответствии с современным и динамичным стилем жизни. Время определяет мысли и движения, сопровождающие действия в течение дня, а пространство принимает их последовательность. Линии, цвета и материалы оживают: результат похож на самую настоящую декорацию, в которой Tr3nd не только обогащает интерьеры, но и становится их бесспорным главным действующим лицом.

Один день, уникальный и неповторимый,  
как множество других.

### 07.30

Пробуждение утром - это чистое наслаждение чувств. Элегантная смесь цветов, материалов, эмоций, заполняющих твою жизнь.

### 08.00

Красота - это твой природный дар, потому что твоя сущность сдержанная, блестящая и соблазнительная.

### 09.00

Ты живешь насыщенной жизнью, получая полное удовольствие от ее большого разнообразия.

### 09.30

Ты каждый день самовыражаешься, вдыхаешь жизнь в малые и большие проекты, удовлетворяя все твои потребности.

### 10.15

У тебя решительная и разносторонняя индивидуальность, ты всегда знаешь, как можно творчески побеждать в повседневных вызовах.

### 11.00

Принятие решений, согласование, улучшение: красота кроется в мельчайших деталях стиля.

### 11.30

Принять позу, чтобы выразить многогранность эстетики.

### 16.15

Твоя сила в сочетании разных стилей. Ты знаешь, как их подобрать и удачно подчеркнуть. Элегантные нюансы дают свободу фантазии.

### 17.00

Ты - это форма и содержание. Потому что за безупречной эстетикой кроется интеллигентная и утонченная натура.

### 18.00

Дом отражает твою личность. Он является теплым, уютным, современным и минималистским. Жизнь в нем - это истинное наслаждение.

### 21.00

Отдых - это погружение в атмосферу теплых и мягких пространств.